

Busbar 400A

Thank you for purchasing the Smart Wiring Busbar from Smart Boat Ltd. Please be aware of the following important information regarding the installation and warranty of your product.

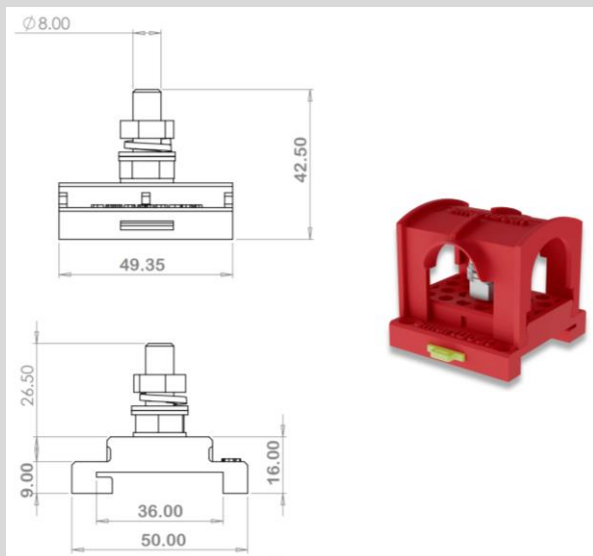
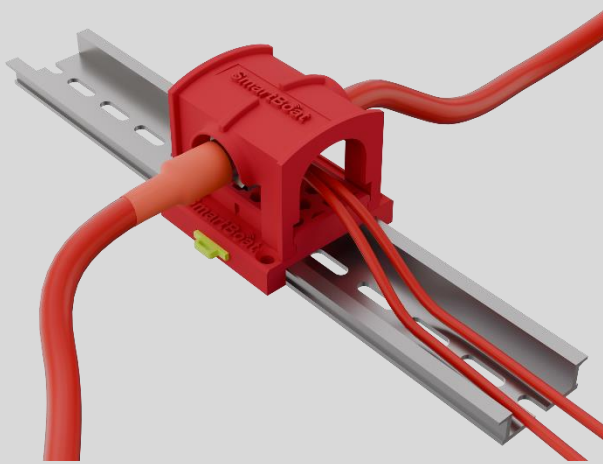
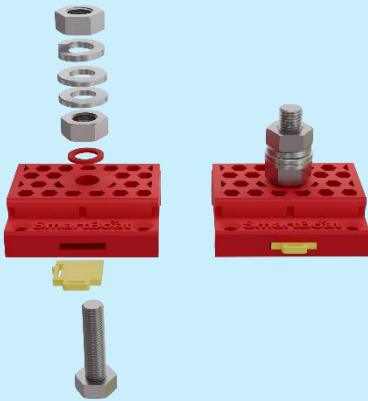

Fork or round terminal connectors (8mm) should be used together with marine grade heat shrink.

Wire connectors should be inserted between the 2 washers which are directly beneath the spring washer.

Current load should not exceed 400A per channel.

Maximum torque for termination M8 Bolt : 18nm, (13in lbs). A wrench should be used on the lower nut when tightening the upper nut.

To mount on a Din Rail, withdraw the yellow Din Rail Clip, place the module on the rail and push in the clip until it clicks. For surface mounting use the supplied screws – these can also be used to provide additional stability to a Din Rail mount.

(Please note – the Din Rail Clips are designed to fit tightly. A small screwdriver can be used to change the fitting.)

Installation Responsibility: It is the customer's responsibility to install the product following the above guidelines. Proper installation is crucial to ensure optimal performance and safety of the product and your installation.

Warranty Implications: Failure to install the product as per the provided instructions will void the product warranty. Any damage or malfunction resulting from improper installation will not be covered under the warranty policy. By proceeding with the installation, you acknowledge and agree to these terms. If you have any questions or require assistance with installation, please contact our customer support team at sales@mysmartboat.com

